



2-bedroom detached house for sale €315.000

Famagusta, Agia-Thekla-5391 , Cyprus

This ad is presented by listings admin, under supervision from ,
Licensed Real Estate Agent Reg no: 1234, Lic no: 603/E

Offered at: € 315,000

Estate ID: 65662

Ref: ba5466392

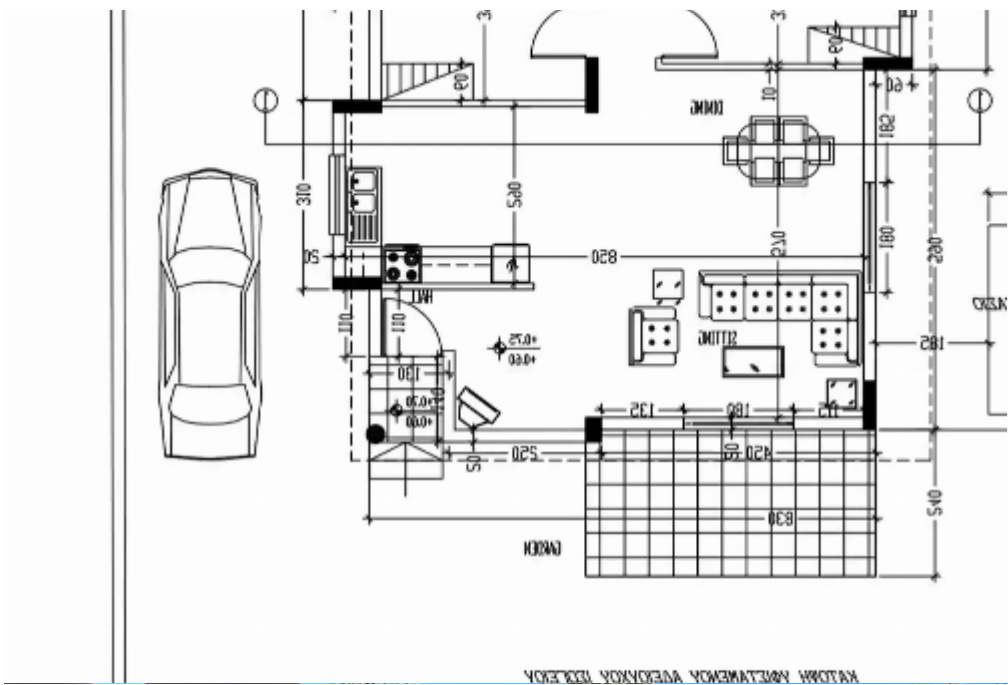



NET internal area: **82**



Bathrooms: **1**



Bedrooms: **2**



Parking spaces: **Uncovered cars**



Available from: **2024-10-06**



Offered at: **315,000**



Type: **PrivateHouse**

""""""""""cosy detached bungalow with a roof terrace and private pool. Spacious corner plot with an extra green area at the back. Mature garden with palm trees. Quite neighbourhood and peaceful location with prospective seaview. Brand new AyiaThekla Marina within 3 min drive as well as the nearest beach of Agia Thekla.. Beautiful walk along the sea is across the road. The title deed is ready to be issued on the name of new owner. For viewing and more details contact on whatsapp. Additinal sqm of covered area can be added as a 1st floor for those who wish to inlarge the house (due to constraction density increase). Plans for an extra 3 bedrooms with an en-suite bathroom (with a shower ...

Estate on map:

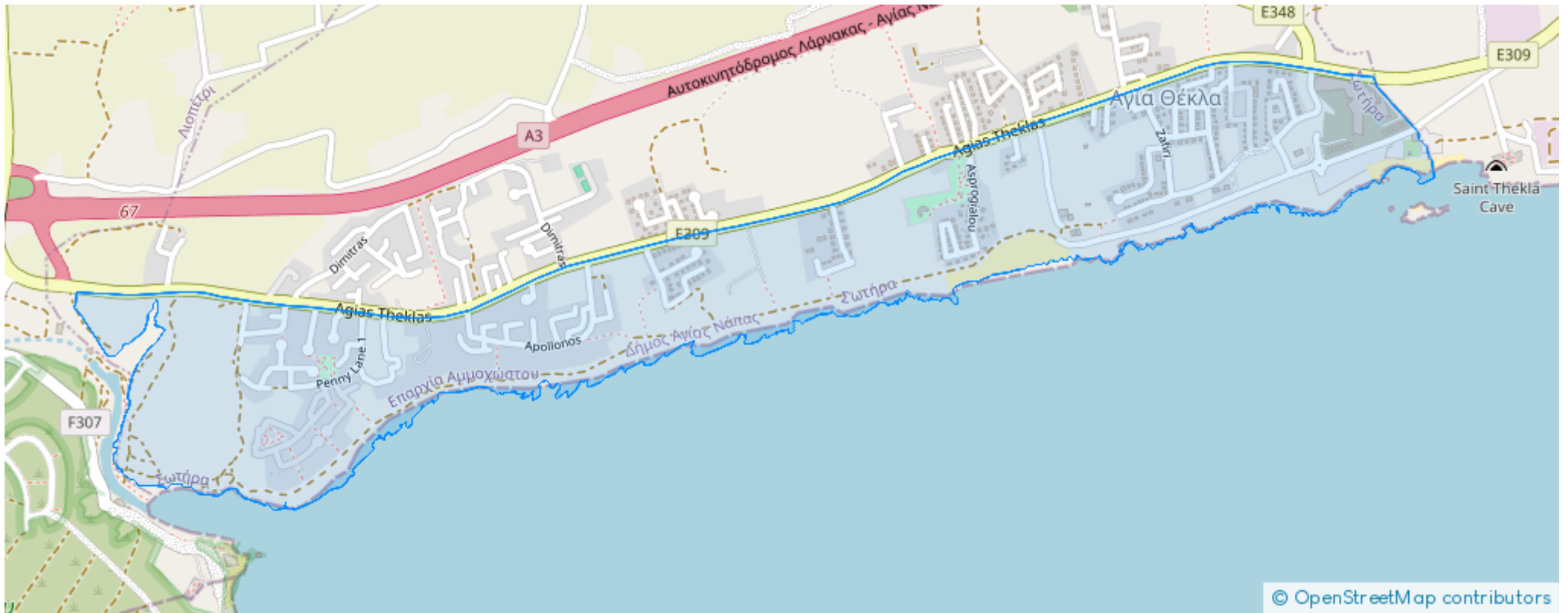

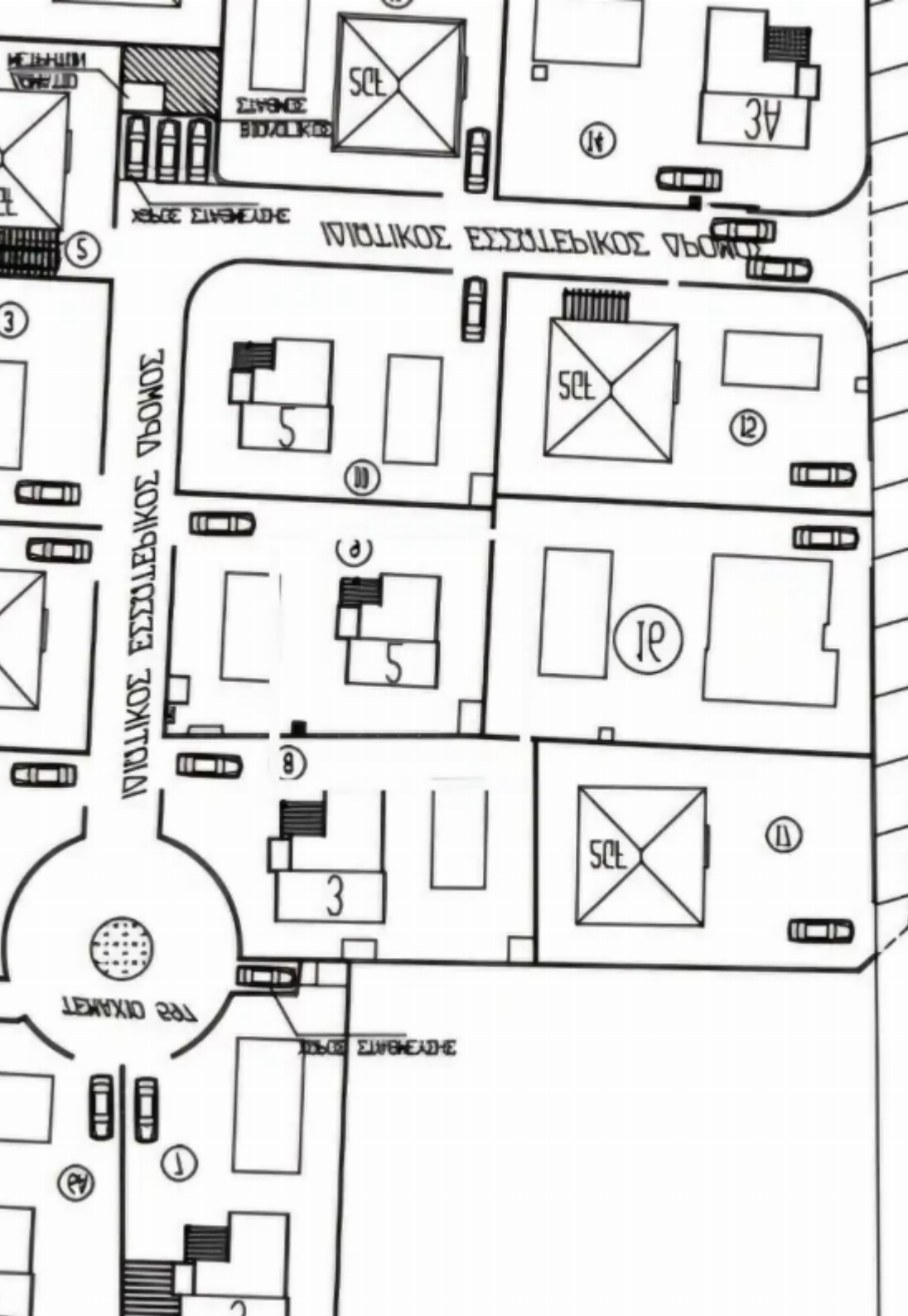

Website: realty.com.cy/p/2-bedroom-detached-house-f?r-s?le-€315.000-ba5466392

Email: info@rimatech.com.cy

Phone: [+35795958898](tel:+35795958898) // [+35725714014](tel:+35725714014)

This ad is presented by listings admin, under supervision from ,
Licensed Real Estate Agent Reg no: 1234, Lic no: 603/E

